

WHEEL PRO

Real-Time Wheel Profile Measurement of Each Wheel
Metro, Tram, Freight, Regional & Hi-Speed Trains



Wheel Pro System is a measurement tool that can obtain in real-time the profile of each wheel providing immediate feedback for every wheel and every axle of the train that is passing through the system.

The Wheel Pro System uses the wheel profile to calculate all important wheel and axle parameters and includes the following features:

- Contactless measurement of different types of wheels and vehicles
- Accuracy of ± 0.2 mm for the profile and ± 0.5 mm for the diameter
- Available for indoor and outdoor installation
- No civil works required
- Adaptable to almost any type of wheel / fleet / location
- Robust against the presence of sanders, electromagnetic brakes, etc.
- The results are obtained in real-time immediately after the train passes.
- Software tool included in order to manage measured data, analyse wheel wear, generate reports, trigger automatic warnings/alarms via SMS/e-mail, etc.



Apart from the typical wheel parameters, the following flange defects can be measured by the Wheel Pro, (limits to be specified by the customer):

- Thin Flange
- Deep flange
- Sharp flange
- Less radius at root of flange
- Hollow tyre
- Thin tyre
- Hollow tread
- Tread rollover
- Flange rollover

Wheel Pro Software

All wheel profiles measured by Wheel Pro system are stored in a database and are accessible from the software platform. This requires every user to login to the system. Once logged in you will be able to manage and analyse every wheel in order to schedule predictive maintenance.

- Profile data management
- Monitoring of all profiles with warning and limit values per vehicle (requires RFID)
- Diameter monitoring for axle, bogie and vehicle
- Wear trend
- Warnings displayed as a traffic light for the driver or by SMS/E-mail to supervisors



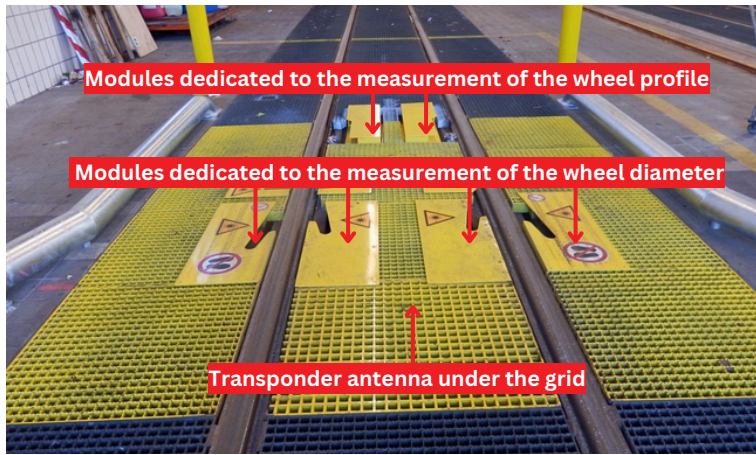

Train Identification:

The identification of every train that is measured is automatically done via RFID tags. The Wheel Pro system can integrate an RFID antenna and controller that can detect RFID transponders that may already be fitted in the trains.

In order to automatically identify the train ID and the correct order of the axles measured, it's necessary that every vehicle has at least 2 RFID transponders installed, one at the front and another at the rear.

When the wheel sensor detects that a train is coming, the modules are activated and the measurement cycle starts. This process is fully automated.

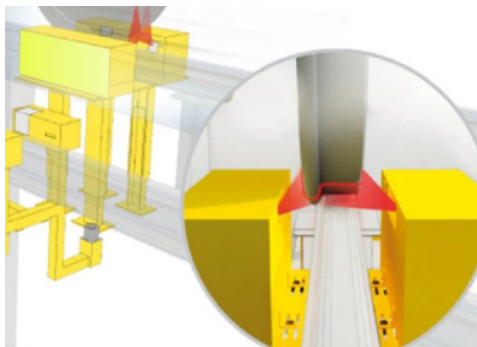

In track measuring device (in-door)

- Automatic wheel profile measurement
- Measurable wheel diameter difference: 100mm
- Back-to-back distance tolerance: Min-Max <30mm
- Accuracy diameter $\pm 0.5\text{mm}$
- Measurement of different wheel configurations
- Accuracy profile measure:
 - SH: $\pm 0.2\text{mm}$
 - SD: $\pm 0.2\text{mm}$
 - QR: $\pm 0.2\text{mm}$
 - Back-to-back: $\pm 0.5\text{mm}$

Global Sales & Service Agents

TRAK BLAZE
MINING, RAIL, ROAD & AIRCRAFT WEIGHING SYSTEMS
Over 95 Years of Innovation

T: +61 (0) 3 9318 9277

info@trakblaze.com

www.trakblaze.com

5 Mareno Road, Tullamarine,
Victoria, Australia 3043

Follow us on